



580-S  
OPERATOR'S HANDBOOK  
WD66-580S-M0204

Tanco Autowrap Ltd.  
Royal Oak Road  
Bagenalstown  
Co. Carlow  
Ireland

Tel.: +353 (0)5997 21336  
Fax: +353 (0)5997 21560  
E-Mail: [info@tanco.ie](mailto:info@tanco.ie)  
Internet: [www.tanco.ie](http://www.tanco.ie)

# GUARANTEE

Subject to hereunder provided, the sellers undertake to correct either by repair or at their election by replacement any defect of material or workmanship which occurs in any of its goods within twelve months after delivery of such goods to first user, with the exception of contractors or commercial users when warranty period is six months.

In respect of Autowraps the warranty period is for 12 months or 8000 bales, whichever occurs first.

In respect of Aerways, tine breakage will be assessed on an individual basis in every case.

The term goods when used in this document means the article or articles described in invoices as sold by the sellers but does not include equipment or proprietary parts or accessories not manufactured by the sellers. The sellers, however, undertake to pass on so far as they legally can to the first user the benefit of any warranty given to the sellers by the suppliers of such equipment, parts or accessories.

This understanding shall not apply to:-

- (a) Any goods that have been sold by the first user.
- (b) Any goods which have been injured by unfair wear and tear, neglect or improper use.
- (c) Any goods the identification marks of which have been altered or removed.
- (d) Any goods that have not received the basic normal maintenance such as tightening of bolts, nuts, tines, hose connections and fittings and normal lubrication with the recommended lubricant.
- (e) The use of any product on tractors exceeding the recommended horsepower.
- (f) Any goods that have been altered or repaired other than on instruction or with the written approval of the seller or to which any part not manufactured or having written approval by the sellers have been fixed.
- (g) Any second-hand goods or parts thereof.

Any allegedly defective part or parts returned to the seller must be sent carriage paid. No claim for repair or replacement will be entertained unless upon discovery of the alleged defect written notification is sent to the Sellers giving, at the same time, the name of the Buyer from whom the goods were purchased and the date of purchase, together with the full details of the alleged defect and the circumstances involved, also the serial number of the machine etc.

The sellers shall be under no liability to their Buyers and first or subsequent users of their goods or to any other person or persons for loss or damage howsoever arising in respect of either personal injuries or for arising out of, or in any other way connected with or arising from the manufacture sale, handling, repair, maintenance, replacement or use of its goods or the failure or malfunction of any of its goods.

Representation and/or warranties made by any persons (including Buyers and employees and other representatives of the Seller) which are inconsistent or conflicting with these conditions are not binding upon the sellers unless given in writing and signed by a director of sales.

## CLAIMS

If you wish to make a claim under the guarantee:

- 1: Immediately, stop using the machine.
- 2: Photocopy and fill out the warranty claim form attached to the back of this manual. List the details of the machine, its serial number and the part number of the damaged part.
- 3: Consult with your Tanco dealer (supplier) and have him forward your claim and the damaged item to Tanco.



## Table of Contents

1.	General Safety Recommendations	4
	1.1. Safety instructions	7
	1.2. Safety Decals	8
2.	Technical Specifications	9
3.	Pre-delivery instructions	10
4.	Transport Instructions	16
5.	Machine Identification	16
6.	Preparation of New Machine	16
7.	Electrical Circuit Diagram 580-S	17
8.	Controller Manual 580-S	18
9.	Operating Instructions	26
10.	Film overlap system	28
11.	Service & maintenance	29
12.	Technical Diagrams	
	12.1. Film Threading Diagram	31
	12.2. Gear Box chain drive tensioning system	32
	12.3. Turntable Chain Drive tensioning system	33
	12.4. Bale Ramp Cylinder-recharging instruction	34
	12.5. Cut & Start Cylinder – recharging cylinder	35
13.	Hydraulic Circuit Diagram 580-S	36
14.	Closed Centre Conversion	37
15.	Fault Finding	38
16.	Warranty claim form	40
17.	Declaration of conformity	41



## GUARANTEE

Subject to hereunder provided, the sellers undertake to correct either by repair or at their election by replacement any defect of material or workmanship which occurs in any of its goods within twelve months after delivery of such goods to first user, with the exception of contractors or commercial users when warranty period is six months. In respect of Autowraps the warranty period is for 12 months or 8000 bales, whichever occurs first.

The term goods when used in this document means the article or articles described in invoices as sold by the sellers but does not include equipment or proprietary parts or accessories not manufactured by the sellers. The sellers, however, undertake to pass on so far as they legally can to the first user the benefit of any warranty given to the sellers by the suppliers of such equipment, parts or accessories.

This understanding shall not apply to:-

- (h) Any goods that have been sold by the first user.
- (i) Any goods which have been injured by unfair wear and tear, neglect or improper use.
- (j) Any goods the identification marks of which have been altered or removed.
- (k) Any goods that have not received the basic normal maintenance such as tightening of bolts, nuts, tines, hose connections and fittings and normal lubrication with the recommended lubricant.
- (l) The use of any product on tractors exceeding the recommended horsepower.
- (m) Any goods that have been altered or repaired other than on instruction or with the written approval of the seller or to which any part not manufactured or having written approval by the sellers have been fixed.
- (n) Any second-hand goods or parts thereof.

Any allegedly defective part or parts returned to the seller must be sent carriage paid. No claim for repair or replacement will be entertained unless upon discovery of the alleged defect written notification is sent to the Sellers giving, at the same time, the name of the Buyer from whom the goods were purchased and the date of purchase, together with the full details of the alleged defect and the circumstances involved, also the serial number of the machine etc.

The sellers shall be under no liability to their Buyers and first or subsequent users of their goods or to any other person or persons for loss or damage howsoever arising in respect of either personal injuries or for arising out of, or in any other way connected with or arising from the manufacture sale, handling, repair, maintenance, replacement or use of its goods or the failure or malfunction of any of its goods.

Representation and/or warranties made by any persons (including Buyers and employees and other representatives of the Seller) which are inconsistent or conflicting with these conditions are not binding upon the sellers unless given in writing and signed by a director of sales.

## CLAIMS

If you wish to make a claim under the guarantee:

- 1: Immediately, stop using the machine.
- 2: Photocopy and fill out the warranty claim form attached to the back of this manual. List the details of the machine, its serial number and the part number of the damaged part.
- 3: Consult with your Tanco dealer (supplier) and have him forward your claim and the damaged item to Tanco.



## 1. GENERAL SAFETY RECOMMENDATIONS

Before operating the machine, always ensure that the tractor and machine meet with work safety and road traffic regulations.

### Basic Principles

1. In addition to recommendations given in this manual, legislation on work safety and accident prevention must also be respected.
2. Advice is indicated on the machine, specifying safety recommendations in order to prevent accidents.
3. Before travelling on public roads, the operator must ensure that the machine conforms to road traffic regulations.
4. Before starting work, the operator must be familiar with all the machine controls, handing devices and their functions. Once at work, it is too late to do this!
5. Do not wear loose clothing, which could become caught up in moving elements.
6. The tractor should be equipped with a safety cab.
7. Before starting up the machine and begin work, check the surrounding area (beware of children!). Make sure there is sufficient visibility. Keep all people and animals away from the danger zone of the machine (risk of protection!!).
8. Carrying people or animals on the machine when working or transport is strictly forbidden.
9. Machine must only be attached to tractor using means provided and in accordance with current Safety standards.
10. Special care should be taken when attaching or removing the machine from the tractor.
11. Before transporting the machine on public roads, ensure that all legally required guards and indicators (lights, reflectors...) are in place and in good operations.
12. All operating controls (cords, cables, rods etc.) must be positioned so that they cannot be set off accidentally, risking accident or damage.
13. Before travelling on public roads, put the machine into it transport position as instructed in this operator's manual.
14. Never leave the tractor seat while the machine is operating.
15. Drive speed must be adapted to ground conditions as well as to roads and path. Always avoid abrupt changes of directions.
16. Before operating the machine, ensure that all safety guards are firmly in place and in good condition. If worn or damaged, replace immediately
17. Before operating the machine, check the tightness of all nuts and bolts, particularly on fixing elements (blades tines, knives, spades etc.).
18. Keep clear of the machine operating area.
19. **Warning!** Danger of crushing and shearing can exist when components are operated by hydraulic or pneumatic controls.
20. Before leaving the tractor or before adjusting, maintaining or repairing the machine, turn off the engine, remove the ignition key and wait until all moving parts have come to a complete stop.



## Tanco Autowrap 580-S Operator's manual

21. Do not stand between the tractor and the machine unless the hand break is tight and/or stops have been placed under the wheels.
22. Before any adjustments, maintenance or repairs are carried out, ensure that the machine cannot be started up accidentally.

### **ADDITIONAL RECOMMENDATIONS FOR LINKAGE MOUNTED MACHINES**

1. Before attaching the machine, ensure that the front tractor axle is sufficiently ballasted. Ballast is to be placed on the supports provided in accordance with instructions of the tractor manufacturer.
2. Do not exceed the maximum axle load or the overall transport weight prescribed by the tractor manufacturer.
3. Precision steering, tractor adherence, road holding and efficient braking are influenced by the type of implement, weight, ballast of front axle, ground or road conditions. It is therefore of utmost importance to be cautious in every given situation.
4. Be particularly cautious when turning corners, paying attention to machine overhang, length, height and weight.

### **SAFETY RECOMMENDATIONS FOR ATTACHING IMPLEMENTS TO TRACTOR**

1. When attaching or removing the machine from the tractor, position hydraulic lift control lever in such a way that it cannot be set off accidentally.
2. When attaching the machine to the tractor hydraulic linkage, ensure that diameter of the link pins corresponds to the diameter of the ball joints.
3. **Warning!** Danger of crushing and shearing can exist in the lifting zone of the tractor hydraulic linkage!
4. Do not stand between the tractor and the machine when operating the outer lever of the lift mechanism.
5. In transport, the machine lift mechanism should be stabilized by the tractor tie rods, to avoid floatation and side shifting.
6. When transporting the machine, lock the hydraulic lift control lever in place so that it cannot be lowered accidentally.



## HYDRAULIC SYSTEMS

1. **Warning!** Hydraulic system is under pressure.
2. When fitting hydraulic motors or cylinders, ensure that connections have been made correctly, as per manufactures instructions.
3. Before connecting hoses to the tractor hydraulics, ensure that tractor and machine circuits are not under pressure.
4. It is strongly recommended that the operator marks the hydraulic connections between tractor and machine to avoid making a wrong connection.  
**Warning!** Functions could be reversed (For example: lift/lower)
5. Check hydraulic hoses regularly! Worn or damaged hoses must be replaced immediately. Replacement parts must be in accordance with the manufactures recommendations concerning specifications and quality.
6. Should a leak be found, take all necessary precautions to avoid accidents.
7. Any liquid under pressure (particularly oil from hydraulics) can be penetrate the skin and cause severe injury. If injured, see a doctor immediately, there could be a danger of infection.
8. Before any adjustments, maintenance or repairs are carried out, lower the machine, depressurize the circuit, turn off the engine and remove the ignition key.

## MAINTENANCE

1. Before checking for any machine malfunction and before adjusting, maintaining or repairing the machine turn off engine and remove ignition key.
2. Check tightness of nuts and bolts regularly. Retighten if necessary.
3. If the machine is raised, prop it up in a stable position before carrying out any maintenance work
4. When replacing a work part, wear protective gloves and use only standarized tools.
5. It is forbidden to discard any oil, grease or filters. These must be given to waste disposal organisations to protect the environment.
6. Disconnect power source before any work is done to the electric system.
7. Check safety guards regularly, particularly those that are subject to wear. Replace immediately if damaged.
8. Spare parts used must be in accordance with specifications and standards as defined by the manufacturer. Use only genuine TANCO parts.
9. Before any electric welding is carried out on tractor or attached machine, disconnect generator and battery terminals.
10. Repairs on elements under pressure or tension (springs, accumulators etc-), must only be carried out by competent persons with standardized equipment.



## **1.1. SPECIAL SAFTY INSTRUCTIONS**

1. Stop engine of the tractor before working on machine.
2. Put a suitable prop under raised platform before working in this area.
3. Always raise lift Arm and fit safety prop before transporting machine on public roads.
4. Lift Arms should always be lowered before operating turntable.
5. Ensure platform rollers are parallel to Lift Arm before arm is raised.
6. On Autowrap models fitted with hydraulic bale ramp it is essential that the hydraulic hose is not disconnected from the hydraulic cylinder or hydraulic accumulator. This system is charged under pressure. Also, do not attempt to open the hydraulic accumulator, as this is a pressurised unit.

## **OPERATING SAFETY INSTUCTIONS**

1. Operators should have their hands on the controls at all times when the machine is in use.
2. Autowrap control unit and level controls must remain in the tractor cap at all times. The operator must at no time leave the tractor cab when the machine is in motion.
3. Keep onlookers clear of machine at all times. Danger zone is 5 meters.
4. Beware of rotating turntable and all moving parts.
5. If not operated correctly the bale could fly off the turntable. The end support rollers must always be fitted. Do not exceed recommended turntable speed of 30 r.p.m. Mis-shapen bales combined with excessive turntable can be dangerous.
6. Care must be taken when tipping bales from the machine on sloping ground and during subsequent handling to ensure that they do not roll, thus causing hazard.

## **THINK OF YOUR PERSONAL SAFETY AND THAT OF OTHER AT ALL TIMES**



### 1.2. SAFETY DECALS

The following safety decals have been placed on your machine in the areas indicated. They are intended for your personal safety and for the safety of the other people working with you. With this manual. Walk around your machine and note the content and locations of these warning signs. Review these decals and the operating instructions in the manual with your machine operators. Ensure that these decals are always legible. If they are not replace them.

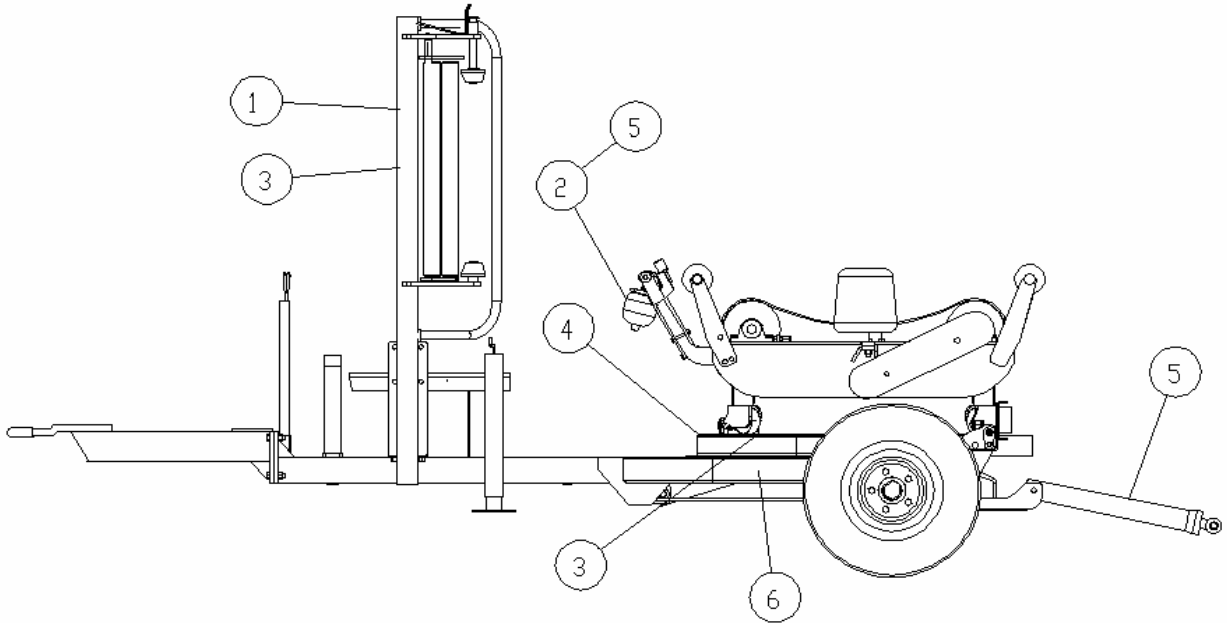

1. READ OPERATORS MANUAL AND SFETY INSTRUCTOONS



2. WARNING: SHARP BLADE

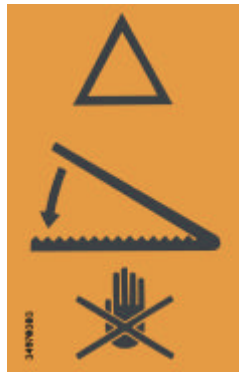

3. DANGER STAND CLEAR



4. DO NOT EXCEED TURNTABLE SPEED OF 30 R.P.M.



5. BEWARE: HOSES UNDER PRESSURE AT ALL TIMES



6. ENSURE THAT NUTS ARE KEEP TIGHT



## 2. TECHNICAL SPECIFICATION

<b>Dimensions</b>	<b>580A/580S Models Trailed</b>
Total length – Excluding Bale Ramp	350cm
Width – excluding lift arm	221cm
“ - lift arm fully raised	243cm
“ - lift arm lowered	380cm
Height to top of side (bale guide) rollers	110cm
Height to top of lift arm	242cm
<b>Weight</b>	
With lift arm	1080kgs
Without Lift arm	960kgs
<b>Wheels</b>	
Size	10-80. 12
Pressure	42 p.s.i.
Lift arm capacity – Axle extended normally	750kgs
“ “ “ - Axle extended Fully	1000kgs
Speed of turntable	30 rev/min*
Oil requirement	(165kpcm <sup>2</sup> ) 25 lit/min
Attachment to tractor	Tractor Hitch
Bale size	120 x 120 cm up to 150 x 150 cm max weight of 1000kgs
Film (Width of Roll)	750mm Optional 500mm

\* The speed of rotation can be varied to suit various conditions but on no account should it exceed 30 r.p.m. (Speed in excess of 30 r.p.m. will void warranty).



### 3. PRE-DELIVERY INSTRUCTIONS

#### IMPORTANT:

DO NOT ATTEMPT TO OPERATE THE MACHINE UNTIL THE FOLLOWING INSTRUCTIONS ARE PERFORMED. OTHERWISE SERIOUS DAMAGE COULD BE CAUSED.

#### MACHINE ASSEMBLY

For ease of transportation some items are removed from their positions and stored elsewhere on the machine. The bale ramp cylinder and Cut & Start unit are stored under the bale belt. On trailed models the cable guide is stored under the bale belt while on 3 point linkage models the top link bracket is stored under the belt. Also stored under the belt, on dispatch, is the **wrappers control unit**. **It is very important that this be removed from the machine and stored in a safe and dry place.** On remote control machines the rear support legs, infra-red receiver, sender units and warning beacon are also stored under the belt. The dispenser mast mounting bracket, film transport bracket, film pull down arm and hitch are attached to the front of machine. On round bale machines only, the top rollers c/w mounting brackets and the plastic end rollers are mounted on the turntable using temporary brackets. Road wheels, dispenser mast, bale lift arm and bale ramp are transported separately. Remove the above items and assemble as detailed on adjoining sketches and parts list taking particular note of the following points:

##### 3.1. DISPENSER MAST

Attach dispenser mast and mounting bracket to front of machine. Attach the film pull down arm. Ensure the pull down arm is faced towards the machine. On remote control machines, attach the infra red receiver and warning beacon to top of the mast. The film mast height is adjustable, Its height is dependent on bale size and type and is set in field. It should be set so that centre line of films is in line with the centre of the bale. See Fig. 1 (Film threading diagram)

##### 3.2. CUT & START

Attach Cut & Start unit to mounting frame on the left hand side of the machine. It is possible to move the unit along the mounting frame. Connect the hose, which is attached to the mounting frame, to the hydraulics ram on the cut & Start unit.

##### 3.3. BALE LIFT ARM

Assemble bale lift arm attach to mounting points on the right hand side of the main chassis. Attach hydraulic ram to lift arm. Grease pivot points.

##### 3.4. TOP ROLLERS AND PLASIC END ROLLERS

Attach plastic end rollers to mounting points on the back and front of the turntable. On round bale machines only, attach top rollers and mounting brackets to each side of the machine.

##### 3.5. ROAD WHEELS

Attach road wheels ensuring that nuts are tight and tyre pressure is 50 p.s.i.

##### 3.6. BALE RAMP OR MAT

Attach bale ramp or mat to rear chassis. Note: Round bale trailed models have hydraulic bale ramps with an option of end tip bale ramp. Linkage mounted machines have bale mats. The standard 1080 trailed models have hydraulic bale ramps. SEE INSTRUCTION BELOW FOR FITTING HYDRAULIC BALE RAMP.

### Checks to be performed

1. Check that all bolts and nuts are tight.
2. That all lubrication points are greased.
3. Check that all guards are in place.
4. Check all operating and safety stickers are in place.

### Instructions for fitting hydraulic bale ramp

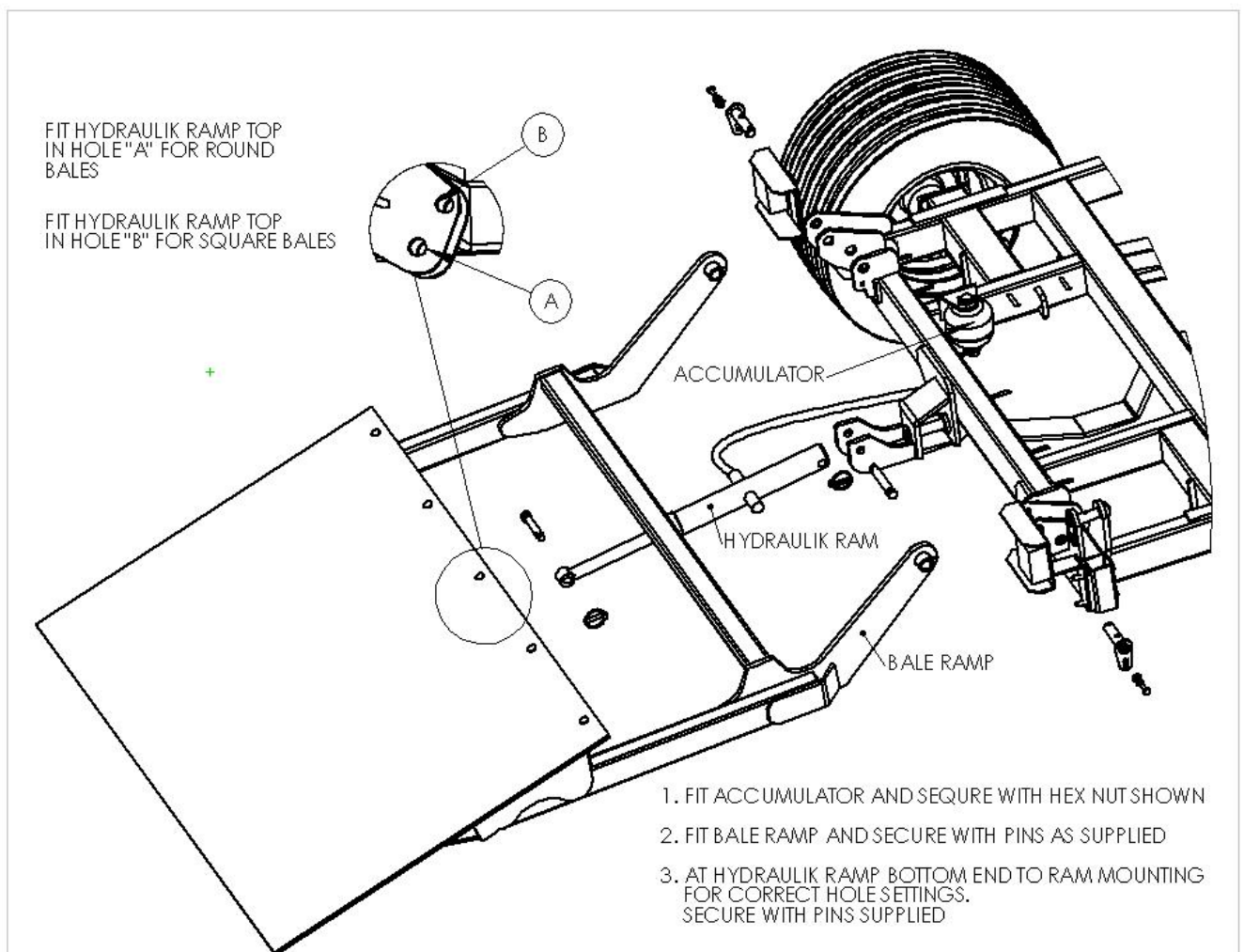

TANCO AUTOWRAP 280S/280ARC/580S/580A  
PRE-DELIVERY ASSEMBLY INSTRUCTIONS  
END ROLLER, TOP ROLLER & CUT & START UNIT

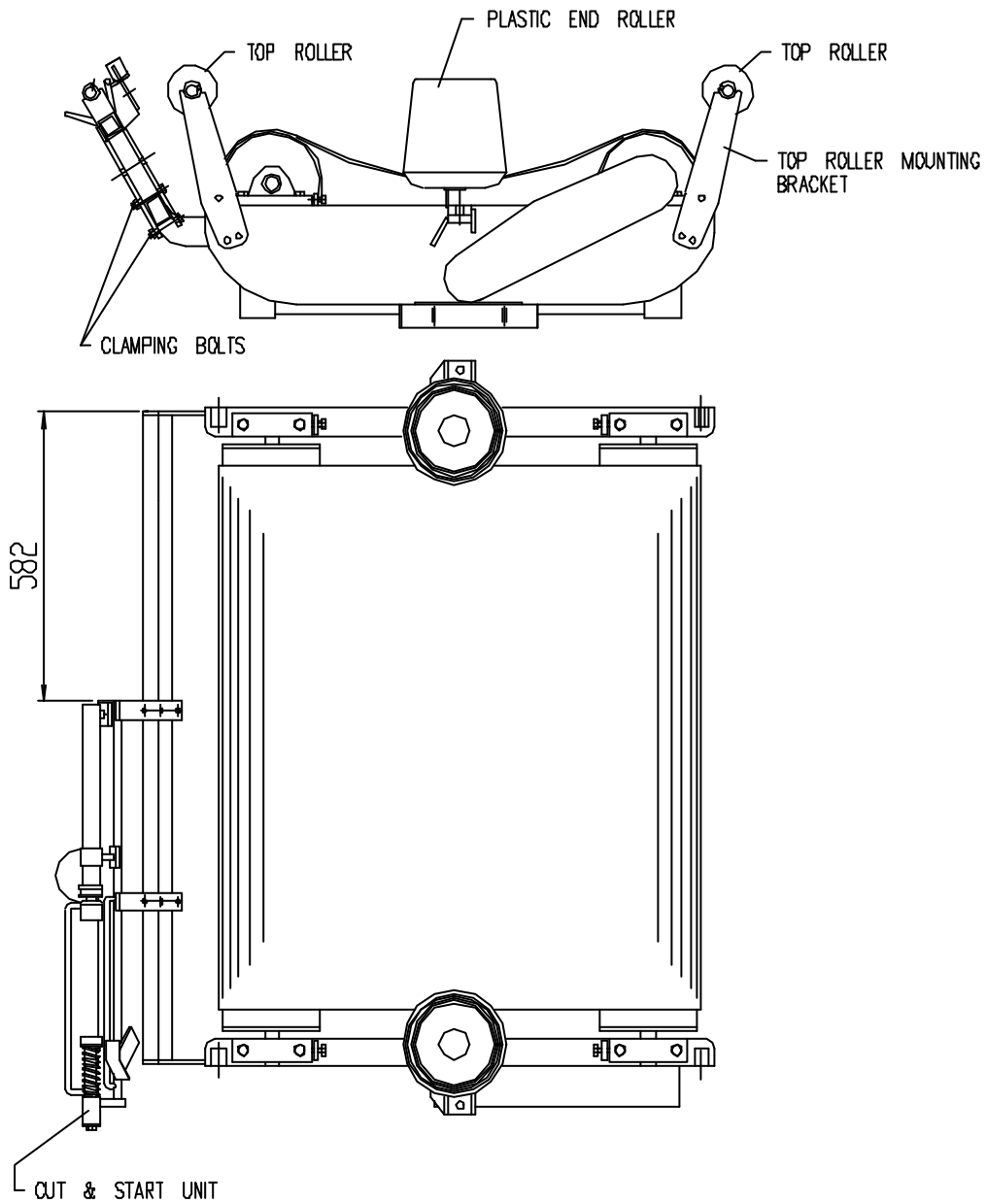

FILE NAME · WD 95 ASS 1

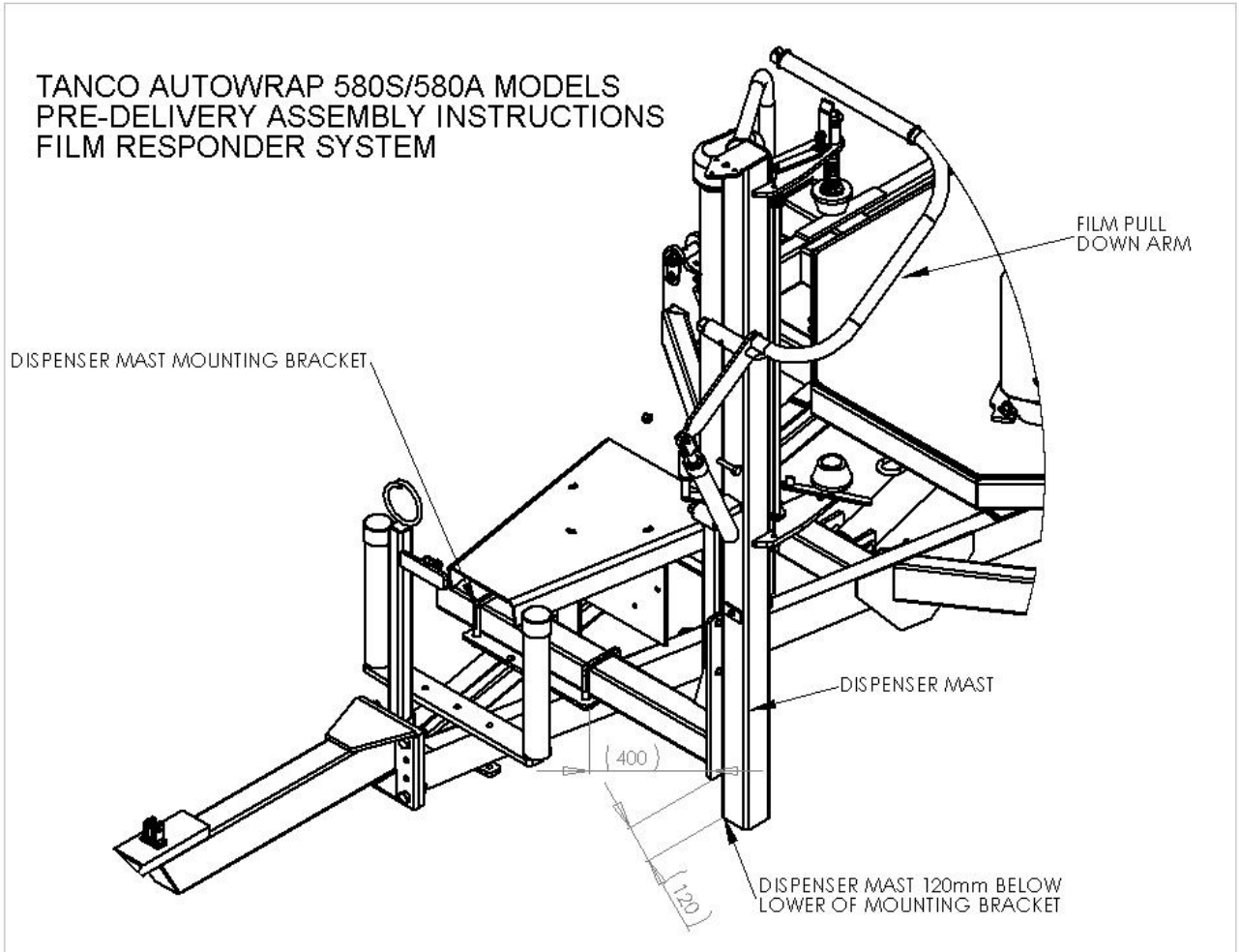

TANCO AUTOWRAP TRAILED MODELS  
PRE-DELIVERY ASSEMBLY INSTRUCTIONS  
FILM TRANSPORT BRACKET

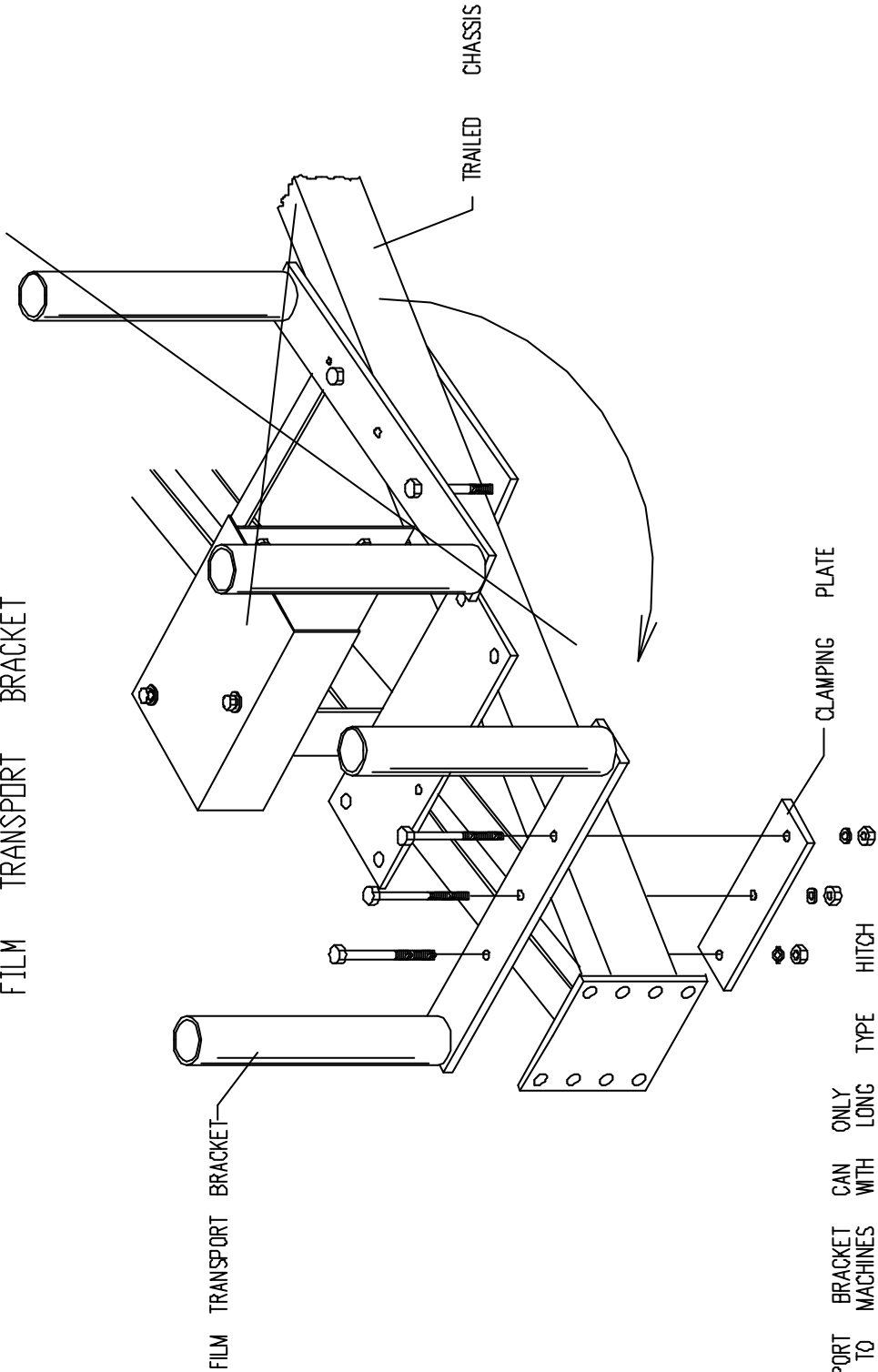

NOTE:  
FILM TRANSPORT BRACKET CAN ONLY BE FITTED TO MACHINES WITH WD610-CHL, WD65-HIT, WD610-HHA.

FILE NAME : WD 60 FTBF



## Operational test

When all above assembly and checks have been carried out, the operation of the machine should be checked as follows:

NOTE: IF YOU ARE NOT TOTALLY FAMILIAR WITH THE OPERATION OF THE TANCO CONTROL SYSTEM, READ THIS MANUAL IN FULL BEFORE PROCEEDING WITH OPERATIONAL TEST.

1. Attach machine to tractor
2. Connect hydraulic hoses to D/A service on tractor.
3. Fit controller box inside cap.
4. Connect control box to the machine and connect power cable direct to the tractor battery. It is important that the leads are connected with the correct polarity.
5. Fit cable control actuator socket to convenient position in cab and locate actuators in socket
6. Lock hydraulic lever in tractor so that oil is flowing through system
7. Check function by operating control levers.
  - (a) Lift arm up and lift arm down. NOTE: Ensure lift arm is down before moving to (b)
  - (b) Turntable rotation forward and reverse.
  - (c) Tip up and down checking hoses are okay.

## 3. Customer checks

Before despatching consult customer on the following points:

1. That machine model suits his requirements.
2. If the machine is to be operated on a tractor with a closed centre hydraulic system then a closed centre valve is required, see separate instructions.
3. Check that the tow hitch type is compatible with the tractor. Three different hitch types are available.





#### **4. Transport Instruction**

- 4.1 Never use straps around machine when lifting. Use only the following lifting points: - Tow hitch and two sockets on each side of Chassis at rear for trailed models. 3 pt. Linkage frame and two sockets on each side of Chassis frame at rear for 3 pt. Linkage Model.
- 4.2 When the machine is towed on the road the lifting arm (if fitted) must be in fully raised position, the safety prop fitted and the axle returned to narrowest position.
- 4.3 Raise the Parking Jack on trailed models before moving machine.

#### **5. Machine Identification**

The Serial Number plate is located on Chassis forward of offside wheel on trailed models and on 3pt. Linkage frame for 3pt. Linkage model.

Always refer to this number when ordering parts. The Spare parts catalogue number and description should be used. The reference numbers are used to help identifying the spare part.

For your records write serial number here.

SERIAL NO.

#### **6. Preparation of a new machine**

- 6.1 Check height of film mast to ensure that centre line of film spool is level with the centre line of the bale on the turntable. This will alter with different bale diameters. If this alignment is not correct some adjustment may be required. See fig 1.
- 6.2 When connecting to John Deere\* tractor the valve must be converted to closed centre. (see p. 32 )

#### **Hydraulic connections**

Connect the feed and return hoses from the Autowrap valve to the tractors double acting facility.

NOTE: The return hose is fitted with a non-return valve to protect the Autowrap from damage in the event of incorrect connecting to the tractor hydraulics.

NOTE: To ensure the maximum efficiency and longevity of hydraulics components this machine requires a clean supply of hydraulic oil.

IT IS RECOMMENDED THAT THE TRACTOR HYDRAULIC FILTER ELEMENT TO BE REPLACED AND THERE AFTER MAINTENANED IN ACCORDANCE WITH THE MANUFACTURES RECOMMENDATIONS.

### 7. Electrical Circuit Diagram

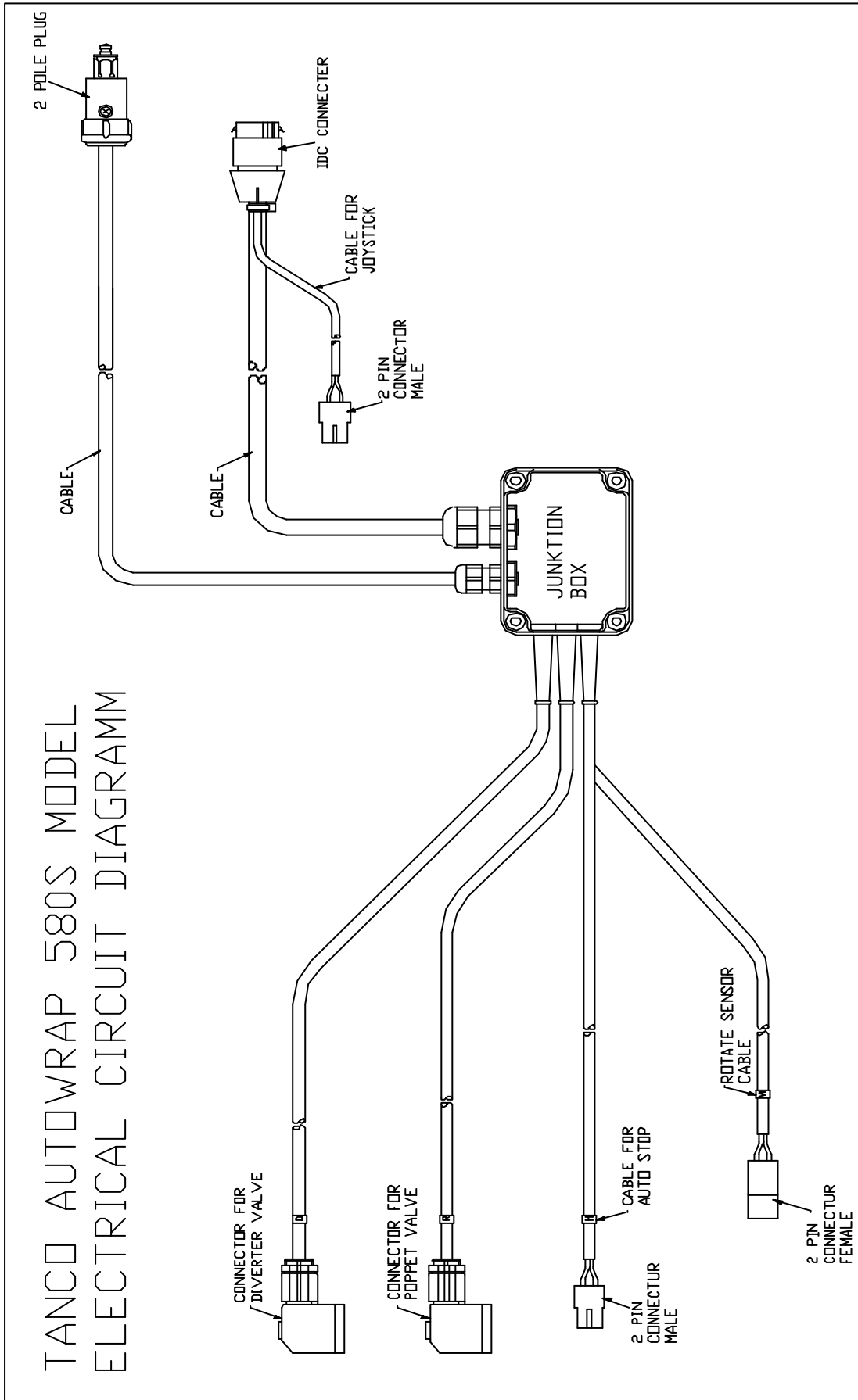



## 8. Controller Manual

### 1 Introduction

What can it do ?

### 2 The control switches

### 3 Using the instrument

#### 3.1 Channel 1 - Current/Target Wraps display

- 3.1.1 Manually reset Current Wraps to zero – 5
- 3.1.2 Programme Target Wraps – 6
- 3.1.3 Programme Early Warning Alarm – 7

#### 3.2 Channel 2 - Store Totals

- 3.2.1 Display a Store Total – 8
- 3.2.2 Select a Store Total - 8
- 3.2.3 Reset a Store Total - 9

#### 3.3 Channel 3 - Part total

- 3.3.1 Display Part Total - 9
- 3.3.2 Reset Part Total - 9

#### 3.4 Channel 4 - Grand Total

- 3.4.1 Display Grand Total - 10

#### 3.5 Channel 5 - Bale Wrapping Rate

- 3.5.1 Display Bale Wrapping Rate – 10
- 3.5.2 Reset the Timing Period - 11

#### 3.6 Channel 6 - Bale Wrapping Speed

- 3.6.1 Display Bale Wrapping Speed - 11
- 3.6.2 Programme the Overspeed Alarm - 12

#### 3.7 Film Break Alarm

#### 3.8 Total Reset

#### 3.9 Other CAL Mode settings

- Cut and Start Release duration - 13
- Film Break Sensor – On/Off – 13



## 1. Introduction

The instrument has 6 channel functions with an illuminated 4 digit LCD display, 5 switches to control all functions and an internal alarm. An external alarm is optional.

The instrument is normally powered on via the vehicle ignition circuit and recalls the function displayed when the instrument was last used.

### What can it do ?

- Continuously displays the current number of wraps around the bale alongside the desired (Target) number of wraps preset by the operator.
- Sounds an alarm at a preset number of wraps before the target number is reached.
- Automatically senses when the bale wrap sequence ends and records it to each of these memory registers:
  - (i) Grand Total
  - (ii) Part Total
  - (iii) One of eight selectable Store Totals
- Displays the number of bales wrapped per hour, within any desired time period.
- Displays bale wrapping speed in rpm, and sounds an alarm when a preset speed is exceeded.
- Film break alarm and automatic stop.
- Adjustable turntable stop position.

## 2. The Control Switches

There are five switches on the front panel used individually or in combination to programme, set/reset or select a function.

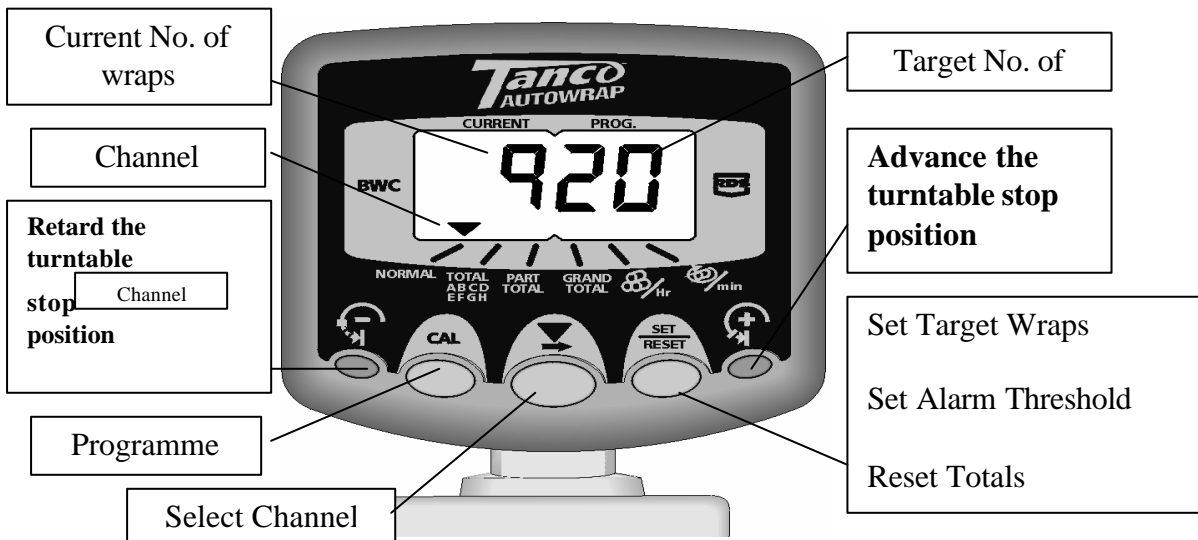

Channel 1	<b>NORMAL</b>	'Normal' display (Current/Target no. of Wraps)
Channel 2	<b>TOTAL ABCD EFGH</b>	Store Totals (A - H)
Channel 3	<b>PART TOTAL</b>	Part Total
Channel 4	<b>GRAND TOTAL</b>	Grand Total
Channel 5	 /Hr	Bale Wrapping Rate

### 3. Using the Instrument

#### 3.1 Channel 1 - Current/Target Wraps Display\_\_



The left-hand section shows the current number of wraps and the right hand section shows the target number. When the current number = Target number, the alarm will sound for 2 seconds and the display will flash. (If set, the early warning alarm sounds beforehand).

Automatic reset of current number to zero normally occurs 5 seconds after the Target number is reached. If additional wraps are added after the Target number is reached, the current number will continue to advance.

##### 3.1.1 Manually reset Current No. of Wraps to Zero



Press to select **NORMAL**.



Press and hold.

### 3.1.2 Programme the Target Wraps

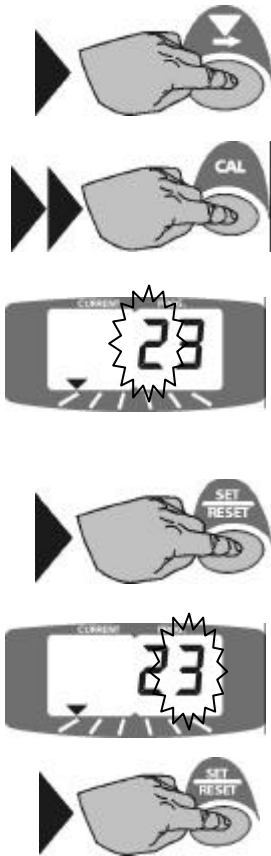

Press to select **NORMAL** .

Hold continuously.

*The third digit flashes.*

Hold to cycle to the required digit then release, otherwise press once...

*The fourth digit flashes.*

Hold to cycle to the required digit.

Release all.

### 3.1.3 Programme Early Warning Alarm

An early warning alarm can be programmed to sound from 1 to 9 wraps before the target number is reached. Depending on the setting, the alarm will sound long beeps for up to 8 wraps, short beeps for the final wrap, and then a continuous beep for three seconds.

For example, if the bale requires 22 wraps and you want an alarm at 20 wraps, then set the number to 2. To effectively disable the alarm, set the number to 0.

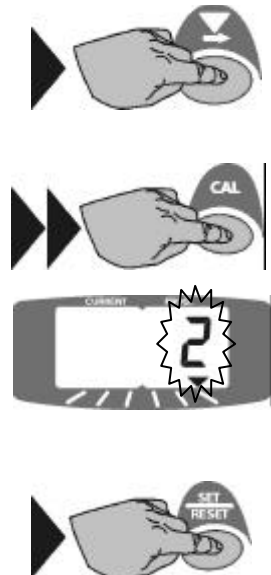

Press to select **@/min** .

Hold continuously.

*The fourth digit flashes.*

Hold to cycle to the required digit.

Release all.

### 3.2 Channel 2 - Store Totals

When bale wrap is complete, one of eight pre-selected memory store totals **A, b, C, d, E, F, G, or H**, is automatically advanced by 1. Store totals can be reset individually.

#### 3.2.1 Display a Store Total



Press to select **TOTAL  
ABCD  
EFGH** .

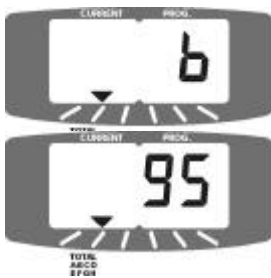

The fourth digit displays the current store designation for 2 seconds.

The current total for that store then displays for five seconds, then defaults to channel 1.

#### 3.2.2 Select a Store Total



Press to select **TOTAL  
ABCD  
EFGH** .



Select the desired store total (A – H).



This is now the default store, and subsequent bale counts are stored there until another store is selected.

#### 3.2.3 Reset a Store Total



Press to select **TOTAL  
ABCD  
EFGH** .



Select the desired store total (A – H).



Press and hold.



### 3.3 Channel 3 – Part Total

When the bale wrap is complete, the part total is automatically advanced by 1. The part total can be reset at any time

#### 3.3.1 Display Part Total



Press to select **PART TOTAL** . \_\_\_\_\_

*Part total displays for 5 seconds then defaults to channel 1.*

#### 3.3.2 Reset Part Total

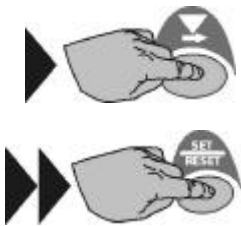

Press to select **PART TOTAL** .

Press and hold for 5 seconds.

### 3.4 Channel 3 – Grand Total

When the bale wrap is complete, the grand total is automatically advanced by 1. The grand total cannot be reset.

#### 3.4.1 Display Grand Total



Press to select **GRAND TOTAL** . \_\_\_\_\_

*Grand total displays for 5 seconds then defaults to channel 1.*

### 3.5 Channel 5 - Bale Wrapping Rate

Displays number of bales wrapped per hour. The time period over which the rate is averaged may be re-started at any time.

#### 3.5.1 Display Bale Wrapping Rate



Press to select **88/Hr** . \_\_\_\_\_



3.5.2



Press to select .



Press and hold for 5 seconds.

### 3.6 Channel 6 - Bale Wrapping Speed

Displays instantaneous r.p.m. of the bale wrapper at 3 second intervals in the range 10-99 r.p.m. An overspeed alarm will sound if the r.p.m. exceeds a pre-programmable limit. The display will default to this channel and flash for the duration of the overspeeding, subsequently reverting to the 'current/target wraps' display.

#### 3.6.1 Display Bale Wrapping Speed



Press to select .



#### 3.6.2 Programme the Overspeed Alarm



Switch power on while pressed.



Release.

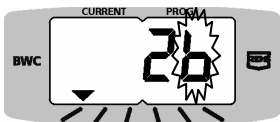

The third digit flashes.



Hold to cycle to the desired digit, then release, otherwise press once...

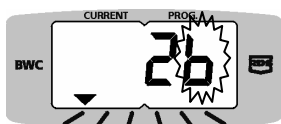

The fourth digit flashes.





Hold to cycle to the required digit.

Release all.

### 3.7 Film Break Alarm

Only operational where optional film break sensor is installed (see parts book).

If the film should break, after 1 second the display will show "STOP", the alarm will sound and the turntable stops.

The film break alarm is only operational above a wrapping speed of 15rpm.

### 3.8 Total Reset

If for some reason the data in the instrument is corrupted or the display shows 'PrOg' then the instrument must be totally reset.

- . Switch power off.
- . Press and hold all 3 control switches.
- . Switch power on.
- . Release all switches.

All instrument settings should be returned to the factory-set values. If the display shows 'PrOg' again, the instrument may be faulty and must be returned to the manufacturer for inspection and repair.

### 3.9 Other CAL Mode Settings

#### Cut and Start Release duration

Switch the power on while pressing and holding the  button to enter Cal Mode 2.

Press the  button to select channel 2.

The default time is 3 seconds. Press /Hold the  button to change the setting.

#### Film Break Sensor – On/Off

Enter Cal Mode 2 as above.

Press the  button to cycle to channel 3.

Press the  button to toggle on/off.

## 9. OPERATING INSTRUCTIONS

### 9.1 Fitting roll of film.

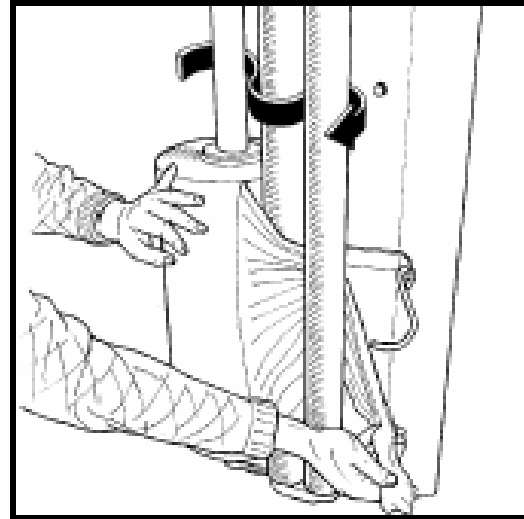
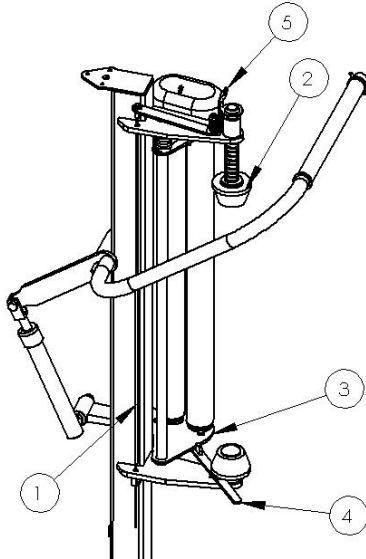

Fig. 5-2

- When loading a plastic roll, first ensure the top cone (2) is pushed up to latched position, then push back the Stretch rollers (3) until held in position by locking catch (4).
- Place the Roll on the Bottom Cone and release the top latch (5) by pushing the wire cord (1).
- Pull the film between the rollers on the pre-stretcher in the direction of the arrow. (See fig. 5-2). (See also the sticker on the dispenser).
- Release the locking catch and allow the rollers to lie against the roll of film. Pull the film from the roll and tie it to the bale.

9.2 Set the bale wrap indicator to the correct setting for the size of the bale being wrapped and the width of film being used see table 1 for list of some recommended setting.

9.3 Power down Lift Arm until wheel is clear of ground and adjust wheel outward to appropriate setting for bale weight.

9.4 Check Turntable speed is approx. 25 r.p.m. NOTE: Speed in excess of 30 r.p.m. will void warranty.

9.5 Position turntable with cut and start unit, facing front of machine.

9.6 Attach film tag end to gripper section of cut and start unit.

9.7 Rotate turntable anticlockwise through 90 degrees and stop turntable with cut and start unit opposite to lift arm.

9.8 Locate bale on Lift arm, then raise lift arm and gently roll bale onto turntable. Lower arm.

9.9 Start wrapping, turntable rotating anticlockwise. Film tension is automatically set so that width of film applied to the bale stays at an approx. width of 400mm for 500mm wide film roll and 600mm for 750mm wide film roll.

The 580 S model is equipped with an AutoStop function, which enables semi-automatic operation of the machine. Once the turntable has made one revolution the spool Joystick is held in position by the bale counter until the preset number of rev.s has been achieved. The Joystick is then automatically released and the turntable stops in the correct "Off-Loading" position.



Tanco Autowrap 580-S  
Operator's manual

- 9.10 On reaching the last wrap revolution a beeping signal from bale wrap indicator sounds (required number of revolution has been reached) to warn the operator that the wrap cycle is complete. Check that the cut and start unit is facing towards front of machine and film aligned with gripper section of cut and start unit. If not correct adjust with a small movement of the joystick.
- 9.11 Tip bale from the machine. When the machine is almost fully tipped the operator presses the button on the control lever which operates the cut and start unit which grips and cuts the film and the bale is then unloaded onto the bale ramp.
- 9.12 Lower the turntable and rotate anticlockwise through 90 degrees and stop with cut and start unit opposite to lift arm.
- 9.13 Repeat operation 7 – 12 as required.

NOTE: The film end need only be attached at the start of a roll, after that, the sequence is automatic.

**Warning Lift Arm**

The Lift Arm on the trailed machine is designed to pick up and deposit bales onto the turntable prior to wrapping and to raise the machine while empty, to facilitate adjustment to sliding axle. It is not intended to be used for transporting bales over distances or for use as stabiliser whilst wrapping.

Therefore, any use of the lift arm outside its primary function will be deemed to be abuse and will void all warranty.

**TANCO DUAL STRETCH FILM DISPENSER**

Some Tanco Autowrap machines can optionally be fitted with a patented dual stretch gear system.

This system enables a quick change of stretch levels on the Film Dispenser.

	<p>If the bolt (1) is fitted in position 2, the bottom set of gears provide the stretch (70%).</p> <p>By removing the bolt from position 2 and fitting it in position 3, the top set of gears become the stretch gears giving 33% (for pre-stretched film) or optionally 55% (for use in hotter climates or with square bales).</p>
--	---

Tanco Dispenser Gear Combinations

Inner Gear	Outer Gear	% Stretch
60 Tooth	35 Tooth	70%
58 Tooth	37 Tooth	55%
54 Tooth	41 Tooth	32%



## 10. Film, Overlap System

The Autowrap is fitted as standard with the 2 x 2 x 50% film overlap system. This is achieved by means of a chain drive which ensure that the correct number of film layers are applied to the bale after a specific number of revolutions of the turntable. The number of revolutions required to wrap a bale depends on width of film being used and bale size – See Table 1 below. The chain should be positioned on inner sprockets for 750mm wide film (Factory set-up). See below.

For use with 500 mm film, the chain must be fitted to the outer sprockets. For 500mm film an optional film adaptor is required to fitting film in Dispenser. See parts Book.

For silage bales we recommend the application of a minimum of four layers of film.

**Table 1**

Bale size	Width of Film Roll	Bale Indicator Setting (Revs)
120cm x 120cm	750mm	17
120cm x 137cm	750mm	19
120cm x 150cm	750mm	21

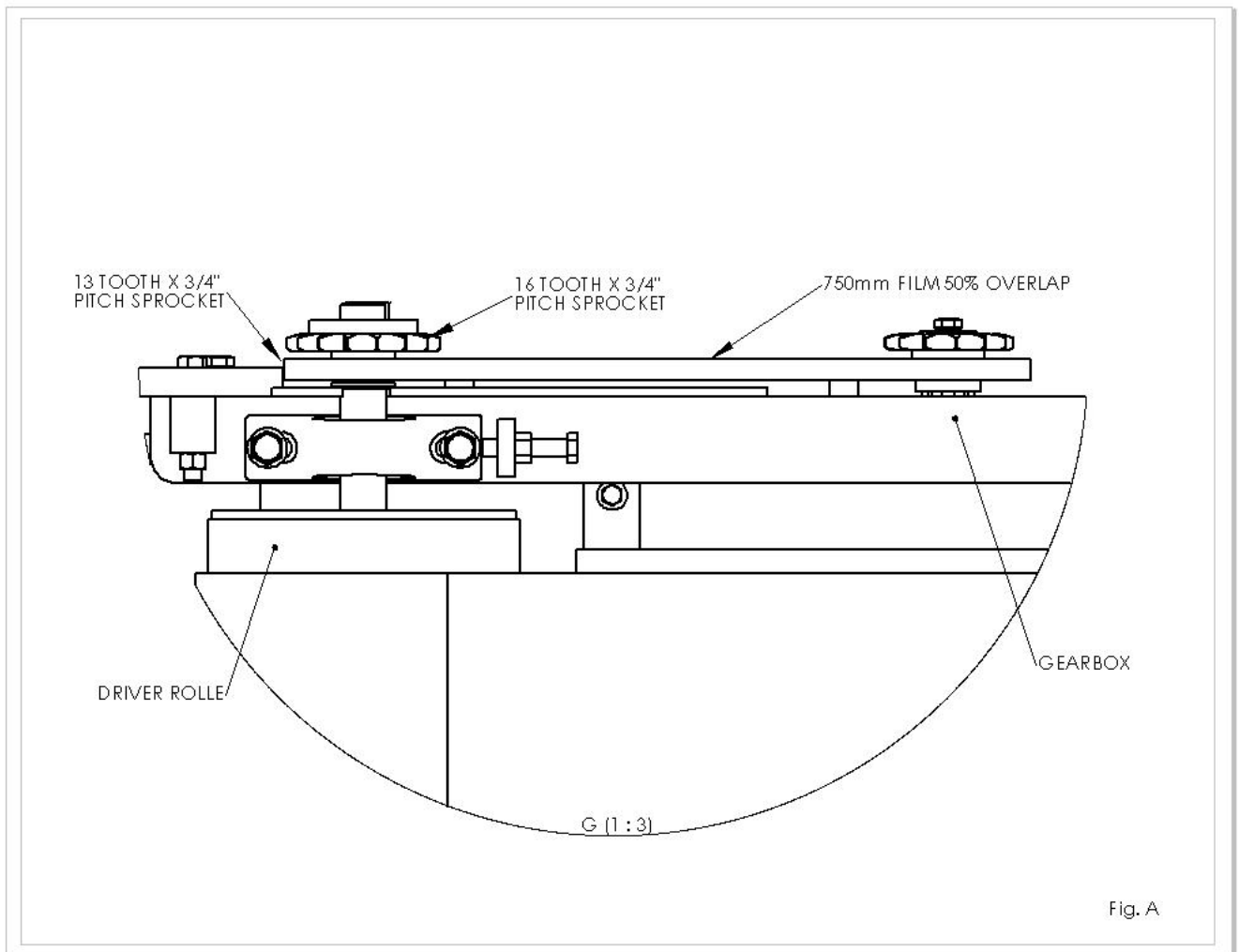

### Important

The above recommendations are only offered as a guide to correct wrapping of silage bales and the manufactures accept no responsibility for variations that many arise and the consequence of same. They are based upon turntable speeds of up to 25 r.p.m., and a approx film width of 600mm applied to end bale when using 750mm wide film roll.

**It is the responsibility of the operator to ensure the correct number of wraps are applied, as variances can occur with fluctuations in speed of rotation, film quality and tensioning, shape and density of bale etc.**



## 11. Service and Maintenance

1. All nuts and bolts should be tightened after the first hour's use, thereafter regulary.
2. Wheel pressure should be normally kept at 42 psi depending on bale weight and field conditions.
3. Inspection moving parts for wear on daily basis.
4. Lubrication

Drive chain & sprocket	Grease every 24 hours
Main rollers	Grease every 24 hours
Hinge pins on lift	Grease every 24 hours
Hinge pins on main tip frame	Grease every 24 hours
Hydraulic rams	Grease every 24 hours
Film spool assy	Grease every 24 hours
Dispenser gearboxes	One shot of Grease every, 500 bales. See 6
Main spindle	Grease even 4000-5000 bales
5. Adjustments
  - Turntable drive chain: Adjust after first days work then check/adjust every 50 hours. See Fig. 8
  - Gearbox Drive chain: Adjust after first days work then check/adjust every 50 hours. See Fig. 2
  - Roller Drive chain: Adjust after first days work then check/adjust every 50 hours. See Fig. 3
  - Main Bale Belt: See belt tracking instructions.
6. Film Dispenser

Apply P.T.F.E. based grease to gears every 2 to 3 months.
7. Film Adjustment

Centre of film roll must be in line with centre of bale and film mast should be vertical.

## 8. Shear Pins

There are two shear pins fitted to sprocket assembly on drive roller see fig. 5. If the pins shear, remove the broken pins re-align holes and fit two replacement spiral pins, 6mm dia x20mm long, Din 7344. There are two spare shear pins attached to inside of chain guard.

NOTE: If shear pins are replaced with other than specified above all warranty is null and void.

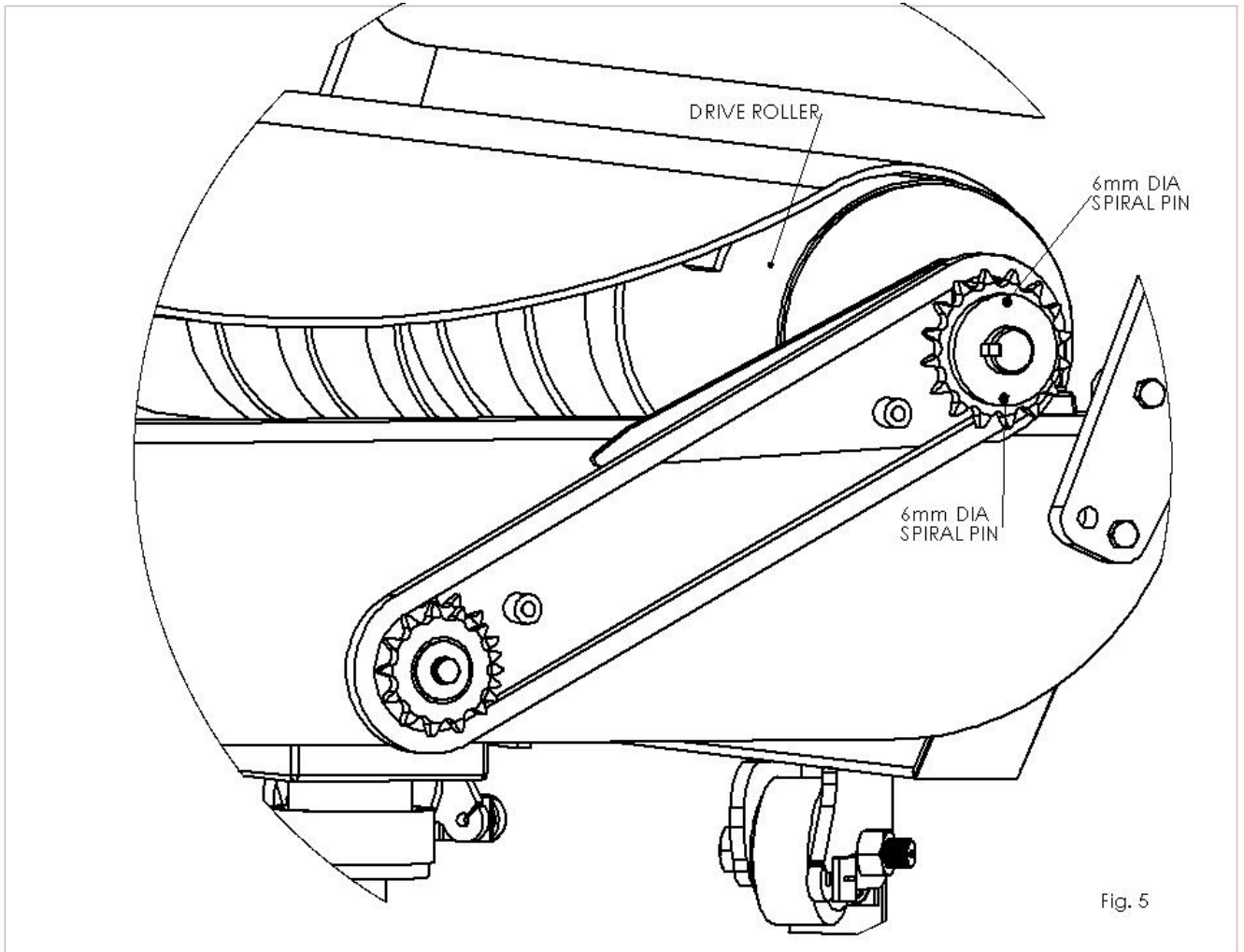

## Service and maintenance (continued.)- Hydraulic filter

1. Before connecting Autowrap to tractor, check quality of oil in tractor hydraulic and replace hydraulic filter.
2. After 25 hours max. it will be necessary replace the element in Autowrap filter.
3. For maintenance purposes it is necessary to change the element after 200 working hours.
4. The element cannot be just cleaned and put back into the filter.

## 12. Technical Diagrams

### 12.1. Film Threading Diagram

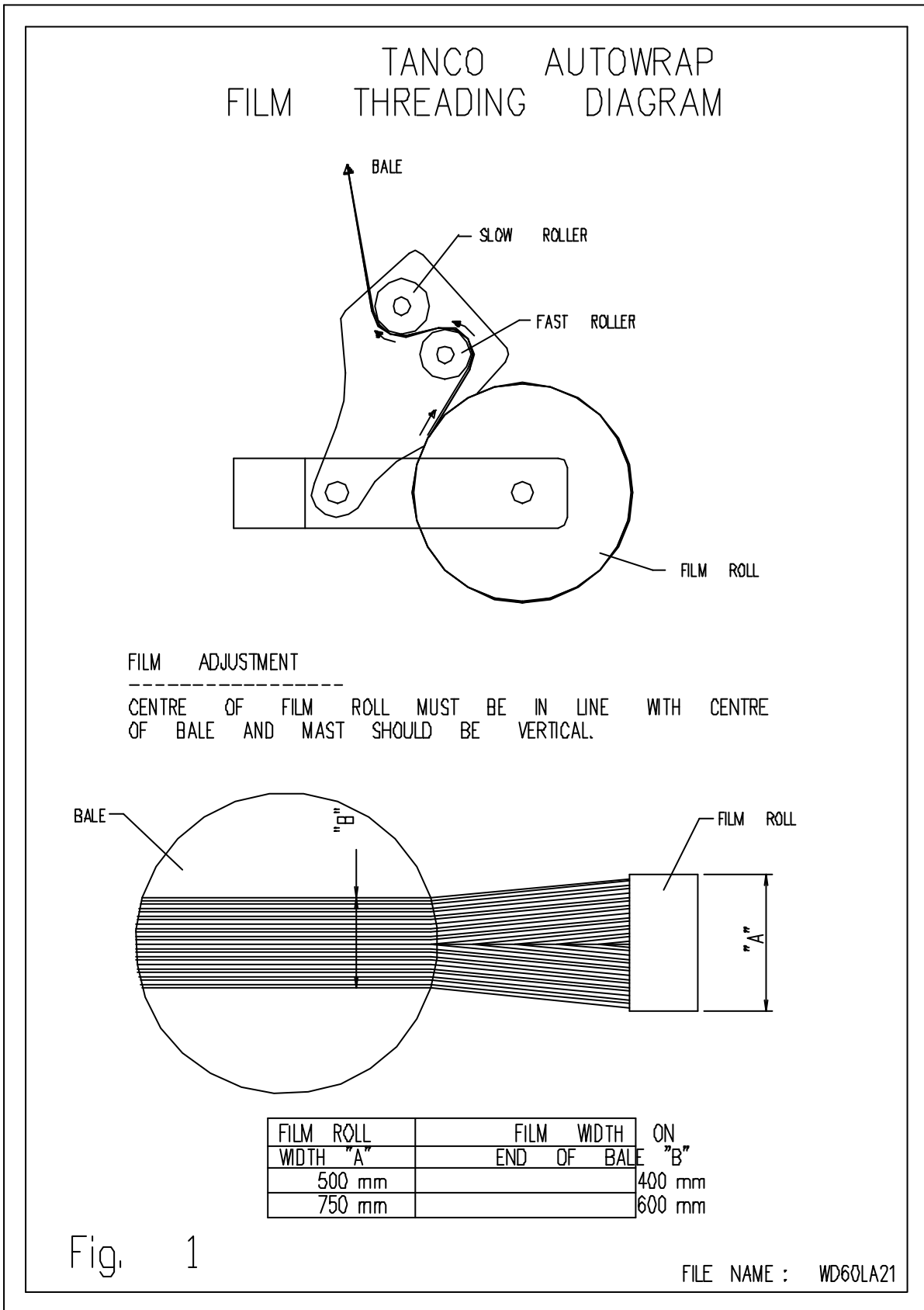



## 12.2. Gear Box Chain drive tensioning system

TANCO AUTOWRAP CONSTANT INDEXING

GEARBOX CHAIN DRIVE TENSIONING SYSTEM

- CHAIN TENSIONING PROCEDURE
1. LOOSEN M 10 BOLT SECURING CHAIN TENSIONER.
  2. TENSION CHAIN BY ADJUSTING TENSIONER USING SPANNER IN DIRECTION OF ARROW \*X\* UNTIL SETTING OF 1.5 - 20 IS REACHED
  3. RE-TIGHTEN M 10 BOLT TO SECURE TENSIONER IN POSITION.

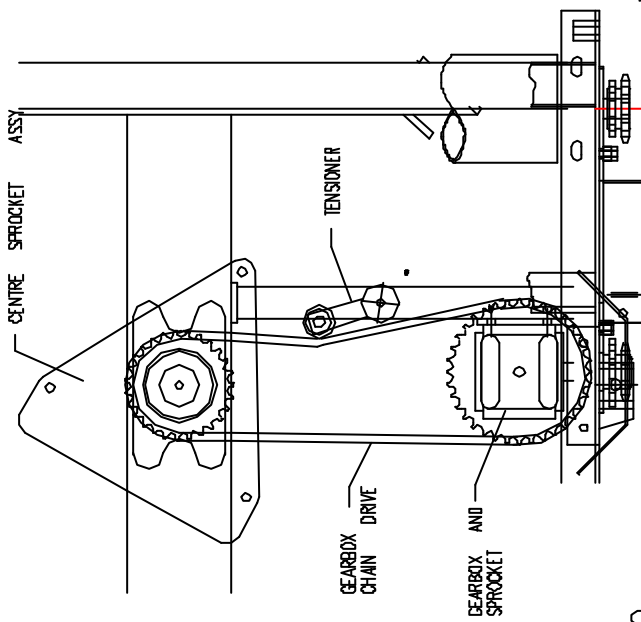
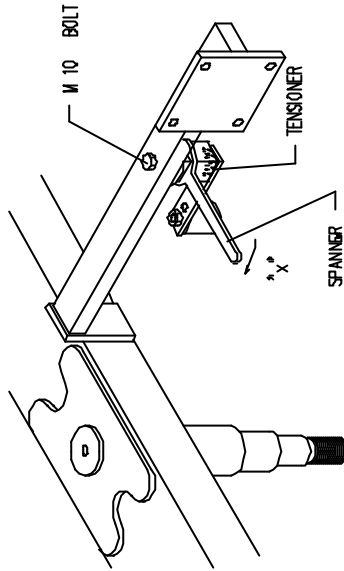

Fig. 2

ROLLER CHAIN DRIVE TENSIONING SYSTEM

- CHAIN TENSIONING PROCEDURE
1. LOOSEN M 14 BOLTS SECURING BEARING
  2. TENSION CHAIN BY LOOSENING LOCKING NUT AND TURNING ADJUSTER BOLT COUNTERWISE TO TAKE UP SLACK IN CHAIN. SECURE IN POSITION WITH LOCKING NUT. ENSURE EQUAL ADJUSTMENTS ARE MADE ON BOTH SIDES.
  3. RE-TIGHTEN M 14 BOLTS SECURING BEARINGS TO 170 Nm (125 FT. lbs.).

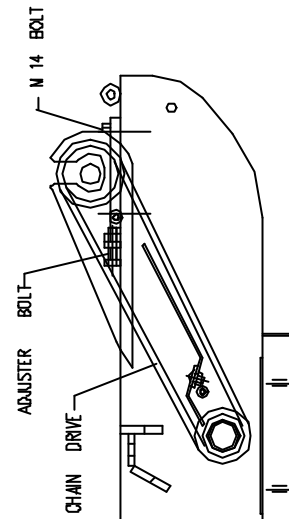

Fig. 3

### 12.3. Turntable Chain Drive tensioning system

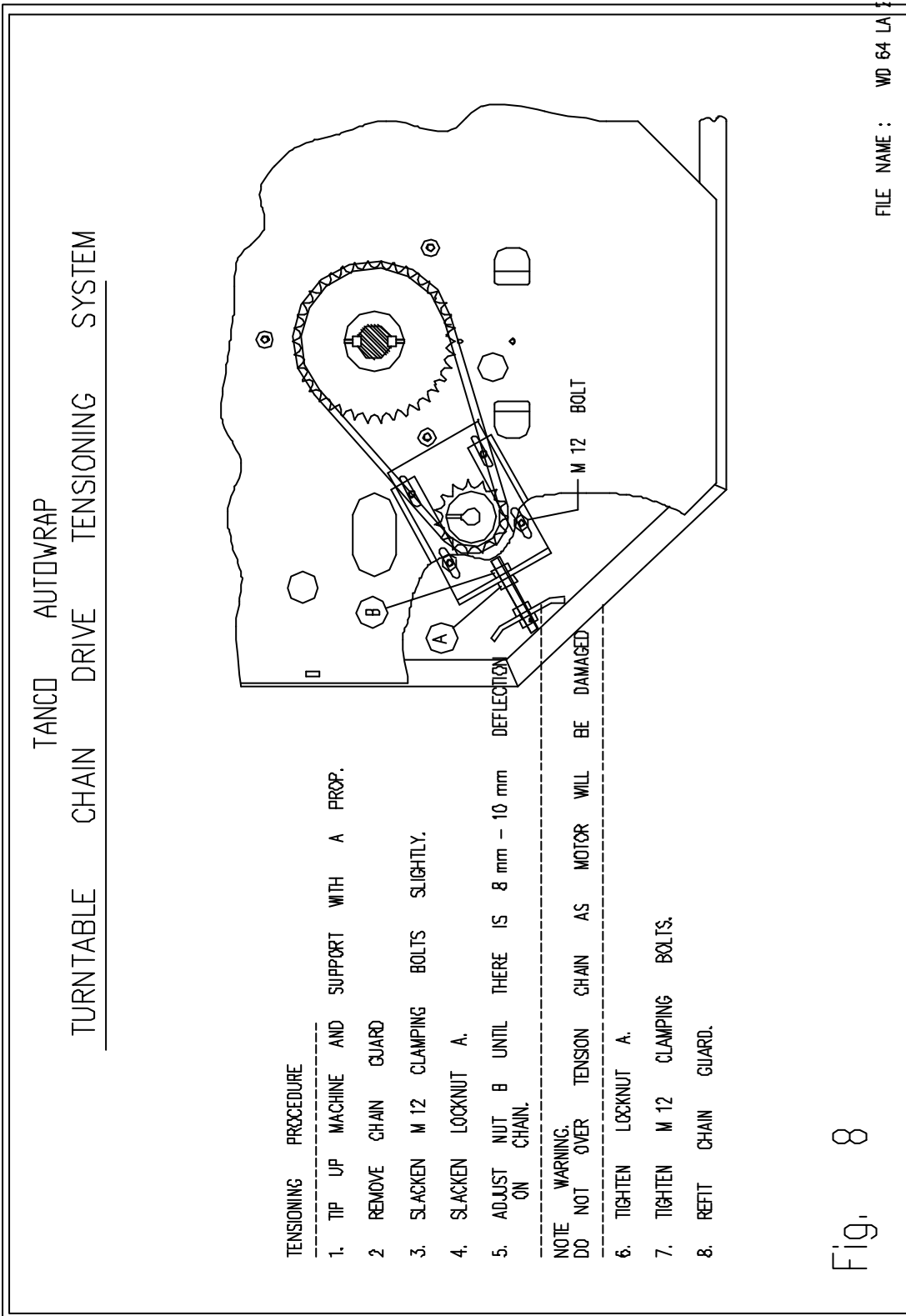
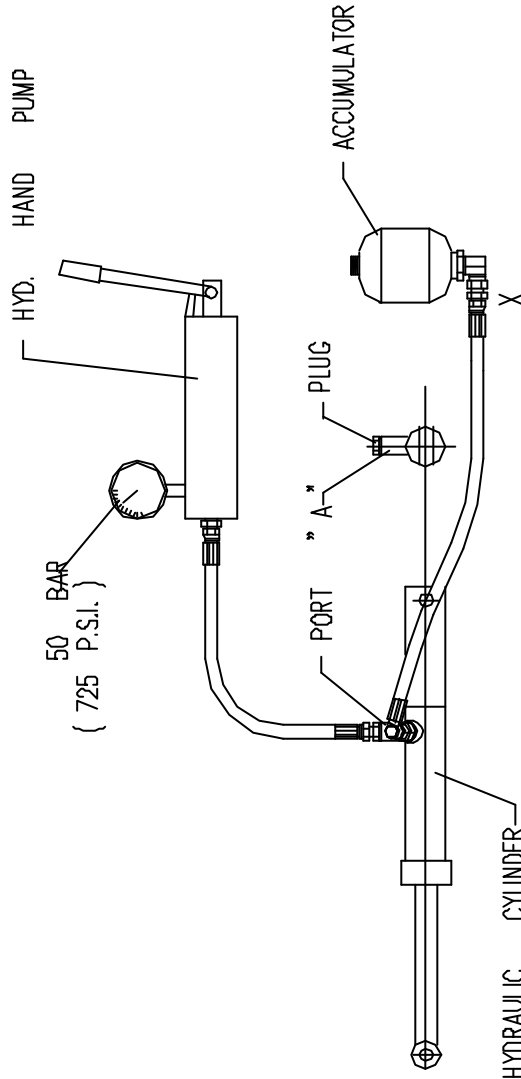

Fig. 8

### 12.4. Bale Ramp Cylinder - recharging instruction

#### INSTRUCTIONS FOR RECHARGING AND REDUCING PRESSURE IN HYDRAULIC BALE RAMP CYLINDER



#### TO RECHARGE CYLINDER

1. REMOVE PLUG FROM PORT " A " .
2. CONNECT HOSE FROM HYD. HAND PUMP TO PORT " A " TO ALLOW OIL TO BLEED OUT SLOWLY.
3. CHARGE CYLINDER TO A PRESSURE OF 50 BAR ( 725 P.S.I. ) TIGHTEN CONNECTION AND CHECK OPERATION
4. BLEED AIR FROM SYSTEM BY SLACKENING HOSE CONNECTION OF BALE RAMP .
5. REMOVE PLUG FROM PORT " A " . RETIGHTEN CONNECTION UNTIL OPERATION OF RAMP AT BASE OF ACCUMULATOR MARKED X . RETIGHTEN CONNECTION UNTIL OPERATION OF RAMP AT BASE OF ACCUMULATOR MARKED X . AND RETIGHTEN CONNECTION UNTIL OPERATION OF RAMP AT BASE OF ACCUMULATOR MARKED X .

#### TO REDUCE PRESSURE IN CYLINDER

1. SLACKEN CONNECTION ON HOSE END JUST ENOUGH TO BLEED OUT SLOWLY.

FILE NAME : WD 66 PL 2 E

### 12.5. Cut & Start Cylinder – Recharging cylinder

TANCO AUTOWRAP - HYDRAULIC CUT AND START  
INSTRUCTIONS FOR RECHARGING HYDRAULIC CYLINDER

1. REMOVE PLUG FROM PORT "A" .
2. CONNECT HOSE FROM HYD. HAND PUMP TO PORT "A" .
3. CHARGE CYLINDER TO A PRESSURE OF 60 BAR ( 870 P.S.I. )
4. REMOVE HOSE FROM PORT "A" AND REFIT PLUG .

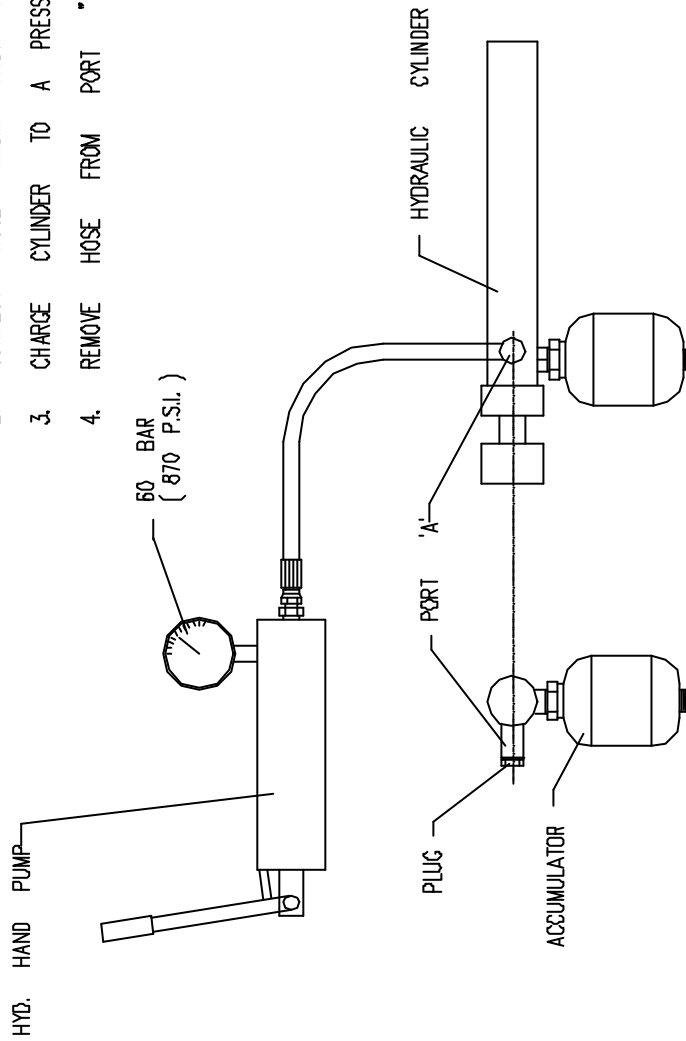

### 13. Hydraulic Circuit Diagram 580-S

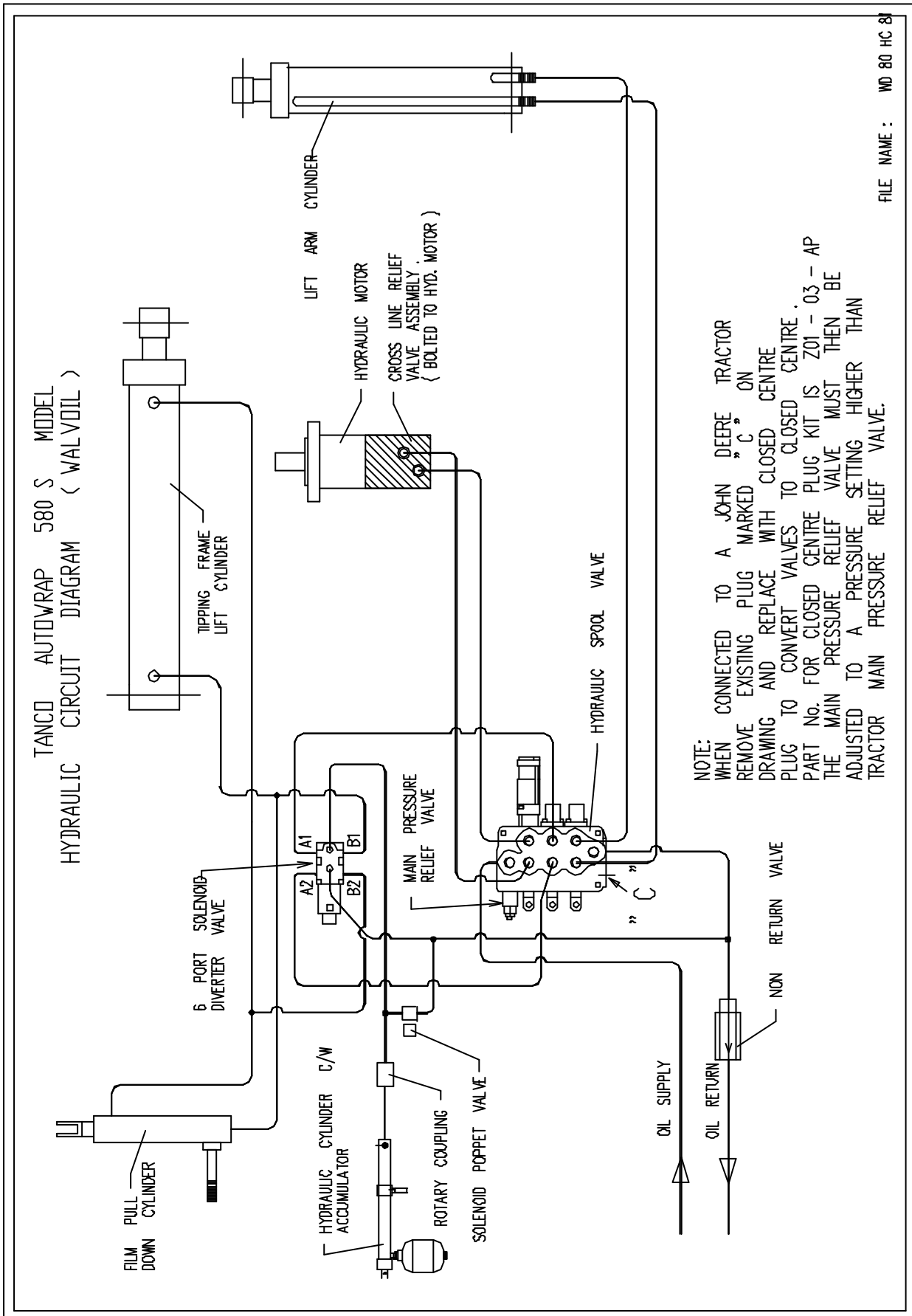



#### 14. OPEN / CLOSED CENTRE CONVERSION

Most tractors are fitted with Open Centered Hydraulic systems. For this reason, our valves are set-up as standard for open centers. However some tractors (e.g. John Deere) use closed centered systems. Consult your dealer if you are unsure about your system requirements. To convert to closed centers a plug must be changed in the valve block. This plug is located on the valve just beside the outlet (T line). Remove the existing one and replace with closed center plug (Part No. Z01-03-A580J).

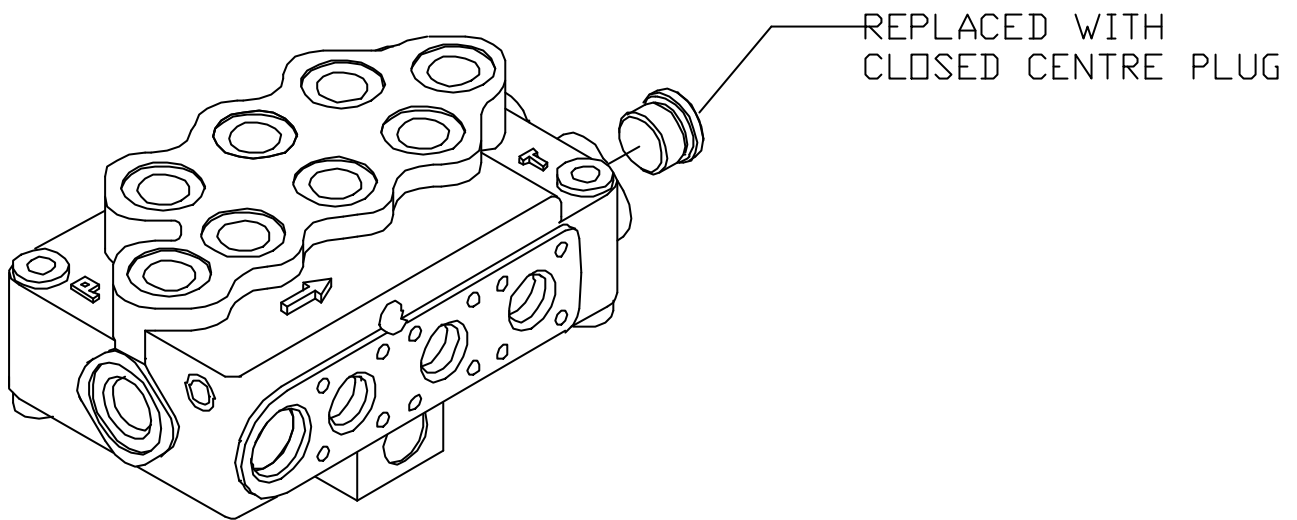

If you are likely to change frequently between open and closed centered hydraulic systems and special plug incorporating a tap can be ordered. (Part No. 1008050- closed center tap plug). This is fitted in the same position on the valve.



## 15. FAULT FINDING (ROUND BALE MODELS)

### **PROBLEMS**

Driver roller and Bale belt not driving.

Film not wrapping evenly

Film breaking

Hydraulic bale ramp not returning to raised position after tripping off Bale.

Pull down arm will not stay down on film when tipping off Bale.

### **Hydraulic Cut & Start**

Cylinder will not go out all the way.

Cut and Start closed and will not open.

Cut & Start will not close

When tipping up turntable and if it does not stop and cut but Continues Tipping up.

### **REMEDY**

Check if shear pins have sheared in sprocket on drive roller if so, Replace.

Adjust the film mast, so that centre of film roll is in-line with the centre of the Bale

Wash off the dispenser.  
Change film roll  
Use only recommended film.

Hydraulic cylinder loss of oil pressure, Recharge see instruction Manual.

Restrictor not fitted or dirt under seat of restrictor.

Hydraulic pressures in tractor not high enough (bad pumps) or too much oil pressure in accumulator side of cylinder over 60 bar.

Pressure lost in accumulator side of cylinder, seals leaking across, or oil leak from gland.

Poppet valve open must have more than 4 revolutions of turntable before Cut & Start will close, or dirt under poppet valve

Check wiring and button switch, if all wires check out ok, dirt might be the problem in the six-port diverter valve, if so disassemble and clean out with petrol or gasoline



**THIS IS VERY IMPORTANT**

Make sure you have a good connection on the battery both positive and negative

**BALE MOVEMENT ON MACHINES**

Ensure enrollers (black cone plastic) are in tight to bale, the bale will reduce in size during wrapping, the corner will become rounded then the bale will tend to move sideways due to central fugal force, if the rollers are too far apart the bale will move against one end, causing the belt to move in the opposite direction, always adjust the belt or end cone rollers, so they keep the bale central on the belt.

On trailed machines adjust bale stop on the lift arm so that the bale is loaded centrally on the belt.

Check that the grip-face are securely fixed to the drive roller.

Check that the belt is the same measurement at each side, if one side is longer than the other then replace the belt.

**IF THE PROBLEM STILL OCCURS REMOVE THE CHAIN COVER,**

1. Adjust chain so that the chain is at the correct tension
2. Measure the distance between the bearing housing and the adjuster plate (typically from 13 to 19 mm)
3. Adjust the opposite end of the driver roller to archive the same measurement.
4. Now you will find that the driver roller is parallel to the chasse.
5. Set idler roller square to driver roller, set from bearing housing to adjusting stop, it should be about 15mm at the start position.
6. If the drive belt is moving to the chain drive side, you will need to make a deeper well at the opposite end.
7. To create this deeper well first stand facing the turntable at the end of the machine with the chain at the bottom right hand corner, this corner at the chain drive is 'A' the top of the drive roller at the other end is 'B' the top of the idler at other end is 'C' and the bottom of the idler at your left is 'D'.
8. Now adjust point 'C' inward by 10mm
9. If the problem still occurs adjust point 'D' outwards by 2mm at any one time.
10. When any one adjustment is made you may have to wrap a minimum of 5 new fresh bales full cycle before making any further adjustments.

If making any more adjustments move only 2mm at one time and wrap 5 bales through full cycle.





### 16. Warranty claim form

#### Customer details

Name & address;

---

---

---

---

Contact number and Name

---

---

#### Machine details

---

Date & dealer details purchased from;

/ /

---

---

Fault reported / work requested;

---

---

Work carried out;

---

---

---

Additional work required

---

---

#### Parts used

Part number or description	Qty	Cost
----------------------------	-----	------

#### Costs incurred

Miscellaneous costs

---

---

---

---

Total =

---

Labour

Hrs	X	=
-----	---	---

---

Parts cost =

---

Grand total =

---

Warranty Y /N \_\_\_ Claim No \_\_\_\_\_



## 17. EU DECLARATION OF CONFORMITY

*ACCORDING TO DIRECTIVES 89/392/336/EEC AS AMENDED*

**Manufacture:** TANCO ENGINEERING CO LTD  
BAGENALSTOWN  
CO CARLOW  
IRELAND

***CERTIFIES THAT THE FOLLOWING PRODUCT:***

AUTOWRAP

MODEL: 580-S  
SERIAL NO.:

To which this declaration relates, corresponds to essential requirements of the Directive 89/392/336/EEC as amended.

To conform to these essential health and safety requirements, the provisions of the following harmonised standards were particularly considered:

EN 292 – 1,2, EN 294, EN1152, prEN 703, prEN 811, prEN 1553, prEN 982.

**DATE:** \_\_/\_\_/\_\_

**SIGNATURE:** \_\_\_\_\_

ANDREW DEASY  
TECHNICAL MANAGER